

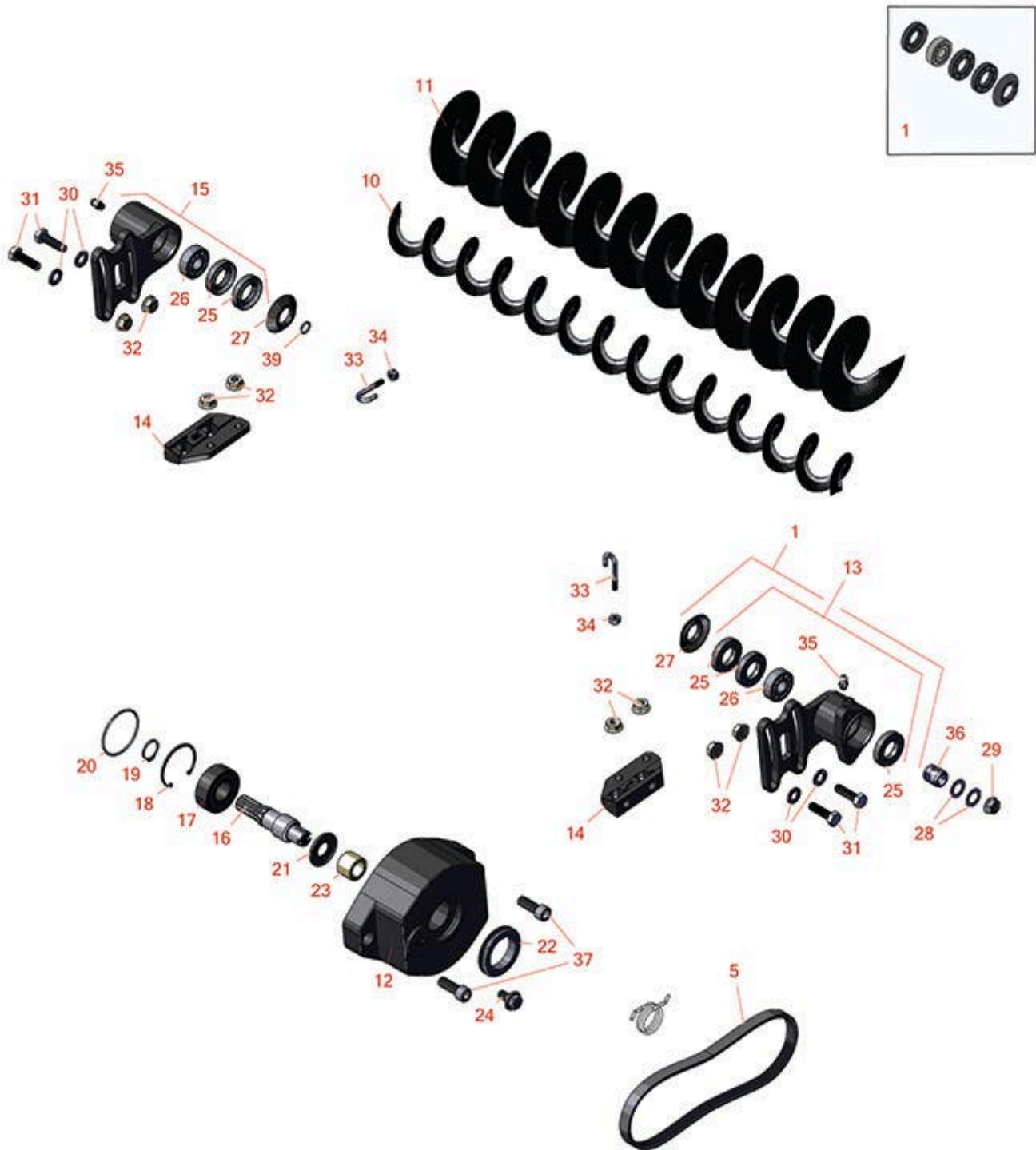

Replaces Toro Reelmaster 6500D Parts

DPA Cutting Unit - Models 03698 & 03699

Rear Roller Brush - Model 03688



All original equipment manufacturers names and part numbers are used for identification purposes only, and we are in no way implying that our products are original equipment parts. Prices subject to change without notice.



Replaces Toro Reelmaster 6500D Parts

DPA Cutting Unit - Models 03698 & 03699

Rear Roller Brush - Model 03688



Item No	R&R Part No.	OEM Part No.	Description	Qty Req	Order Quantity
Overhaul Kit					
1	R110-4086	110-4086	Kit - Bearing	1	
<i>Detail Description: Includes 1 ea: R95-0707 Bearing, R108-4172 Seal; & 3 ea: R106-8530 Seal;</i>					
Belts					
5	R115-0833	115-0833	Belt- Brush 7 in	1	
Other Parts Available					
10	R108-4193	108-4193	Brush - Roller - 2 OD	1	
11	R110-1740	110-1740	Brush-Roller (High HOC) 3.5 in OD	1	
12	R108-4201	108-4201	Bearing Housing Assy	1	
13	R108-4495	108-4495	Bearing Housing Assy - Driven	1	
14	R108-4480	108-4480	Bracket - Rear Roller Brush	2	
15	R108-4496	108-4496	Bearing Housing Assy - Non Driven	1	
16	R108-4234	108-4234	Shaft - Drive	1	
17	R93-2559	93-2559	Bearing	1	
18	R32120-62	32120-62	Ring - Retaining	1	
19	R458013	30-0580, 32120-72, 458013, 93-2525, 936125	Ring - Retaining	1	
20	R112-6967	112-6967	O-Ring	1	
21	R107-7795	107-7795	Seal - Oil	1	
22	R240-7	240-7	Grommet - Rubber - 2 in OD	1	
23	R108-4477	108-4477	Spacer	1	

All original equipment manufacturers names and part numbers are used for identification purposes only, and we are in no way implying that our products are original equipment parts. Prices subject to change without notice.



Replaces Toro Reelmaster 6500D Parts

DPA Cutting Unit - Models 03698 & 03699

Rear Roller Brush - Model 03688



Item No	R&R Part No.	OEM Part No.	Description	Qty Req	Order Quantity
24	R27-0411	27-0411	Bolt - Shoulder	1	
25	R106-8530	106-8530	Seal - Oil	3	
26	R95-0707	95-0707	Bearing - Self Aligning	1	
27	R108-4172	108-4172	Seal - Excluder	1	
28	R112-6957	112-6957	Washer - Hardened	2	
29	R104-8301	104-8301, 104-9301, 109-6658, 133-7570	Locknut - 3/8-16 Nylon Flanged	1	
30	R94-6936	94-6936, 94-9236	Washer - Hardened - 5/16 SAE	4	
31	R322-16	322-16, Apr-00	Bolt - Hex HD 5/16-18 x 1-1/8	4	
32	R104-8300	104-8300, 104-8300 , 119-4041	Locknut - 5/16-18 Flanged Y/Zinc	4	
33	R105-9632	105-9632	Bolt - J	2	
34	R3296-2	32127-10, 3296-2, 9157404	Nut - #10 Lock	2	
35	R302-5	21-6010, 302-11, 302-37, 302-47, 302-5, 302-57, 302-58, 302-6, 31-0300, 32-9660, 60-0800, 62-3880, 92-4181	Fitting - Grease	1	

All original equipment manufacturers names and part numbers are used for identification purposes only, and we are in no way implying that our products are original equipment parts. Prices subject to change without notice.



Replaces Toro Reelmaster 6500D Parts

DPA Cutting Unit - Models 03698 & 03699

Rear Roller Brush - Model 03688



Item No	R&R Part No.	OEM Part No.	Description	Qty Req	Order Quantity
36	R108-4491	108-4491, 127-7139	Spacer - Hardened	1	
37	R3274-7	3247-7, 3274-7	Bolt - Soc HD Cap 3/8-16 x 1	2	
39	R237-22	107-8844, 237-22, 237-78	O-Ring	1	

All original equipment manufacturers names and part numbers are used for identification purposes only, and we are in no way implying that our products are original equipment parts. Prices subject to change without notice.